



Perkins



Image for illustrative Purposes only.

GENERATING SET MODEL (RMS-P13)

Output Ratings	Prime	Standby
380-415 V, 3 ph, 50 Hz, 1500 rpm	12.5 KVA	13 KVA
	10 KW	10.4 KW

ALTERNATOR DATA

Make	Stamford
Model	P1044F1
No. of bearings	1
Insulation class	H
Pole	4
Ingress Protection	IP23
Excitation System	SELF
Winding Pitch	2/3
AVR Model	AS480
Overspeed	2250 mn ⁻¹
Voltage Regulation (steady)	± 1%

ENGINE / TECHNICAL DATA

Ratings at 0.8 Power Factor

Engine Make	Perkins	
Engine Model	403A-15G1 / 403D-15G	
Governing Type	Mechanical	
Number of Cylinders	3	
Cylinder Arrangement	Vertical in line	
Bore and Stroke mm	84 x 90	
Displacement / Cubic Capacity litres	1.496	
Induction System	Naturally Aspirated	
Cycle	4 stroke	
Combustion System	Indirect Injection	
Compression Ratio	22.5:1	
Rotation	Anti-clockwise, viewed on flywheel	
Cooling System	Water - cooled	
Frequency and Engine Speed	50Hz & 1500rpm	
	Prime	Standby
Fuel Consumption @ 50% load L/hr	2.0	-
@ 75% load L/hr	2.8	-
@ 100% load L/hr	3.7	-
Total Lubrication System Capacity litres	6.0	6.0
Total Coolant Capacity (inc. radiator) litres	6.0	6.0
Exhaust Temperature: °C	445	490
Fuel Tank Capacity: litres	TBA	TBA

CONTROL PANEL

Make	Deep Sea
Model	4000 SERIES

The DSE 4000 Series is an Auto Start Control Module for single genset applications. It includes a backlit LCD display which clearly shows the status of the engine all the times. This module can either be programmed using the front panel or by using the DSE configuration suite PC software.

Metering and Alarm indications:

- Generator frequency
- Underspeed, Overspeed
- Generator volts (L-L, L-N)
- Generator current
- Engine oil pressure
- Engine coolant temperature
- Fuel level (Warning or shutdown) - Optional
- Hours run counter
- Battery volts
- Fail to start/stop
- Emergency stop
- Failed to reach loading voltage/frequency
- Charge fail
- Loss of magnetic pick-up signal - Optional
- Low DC voltage
- CAN diagnostics and CAN fail/error

1. ENGINE

Pe:kins four stroke heavy duty high performance industrial type diesel engine.

2. ENGINE FILTRATION SYSTEM

- Cartridge type dry air filter.
 - Two Cartridge type fuel filters.
 - Full flow lube oil filter.
- All filters have replaceable elements.

3. COOLING RADIATOR

Radiator and cooling fan, complete with safety guards, designed to cool the engine at high ambient temperatures (consult your dealer for de-ration factors)

4. EXHAUST SYSTEM

Heavy duty Industrial Exhaust Silencer

Silencer noise reduction level	22 (dB)
Maximum allowable back pressure	10.0 (kPa)

5. CIRCUIT BREAKRT TYPE

ABB 3 pole MCCB. (4 pole is optional)

6. FUEL SYSTEM

The baseframe design is incorporated with an integral fuel tank with a capacity of approx. 8 hours running at Full Load. The tank is supplied complete with fill cap breather, fuel feed and return lines to the Engine and drain plug.

7.ALTERNATOR

7.1 INSULATION SYSTEM

- The insulation system is Class H.
- All windings are impregnated in either a triple dip thermosetting liquid, oil and acid resisting polyester varnish or vacuum pressure impregnated with a special polyester resin.
- Heavy coat of antitracking varnish additional protection against moisture or condensation.

7.2 AUTOMATIC VOLTAGE REGULATOR (AVR)

The fully sealed Automatic Voltage Regulator maintains the Voltage Regulation at $\pm 1\%$. Nominal adjustment by means of a trim pot incorporated on the AVR.

8. MOUNTING ARRANGEMENT

8.1 COUPLING

The Engine and Alternator are directly coupled by means of an SAE flange. The Engine flywheel is flexibly coupled to the Alternator rotor.

8.2 ANTI-VIBRATION MOUNTING PADS

Anti-Vibration pads are affixed between the Engine / Alternator feet and the Baseframe thus ensuring complete vibration isolation of the rotating assembly.

8.3 SAFETY GUARDS

The Fan & Fan Drive along with the Battery Charging Alternator are Safety Guard protected for personnel protection.

9. FACTORY TEST

- The Generating set is load tested before dispatch
- All protective devices control functions and site load conditions are simulated. The generator and it's systems are checked before dispatch.

10. EQUIPMENT FINISHING

All mild steel components are fully degreased and painted with powder coated paint to ensure maximum scuff resistance and durability.

11. DOCUMENTATION

Operation & Maintenance manual, Circuit wiring diagrams and Commissioning / Fault Finding instruction leaflets are accompanied with the Generator.

12. QUALITY STANDARDS

The equipment meets the following standards: BS4999, BS5000, BS5514 IEC 60034, VDE0530, NEMA MG 1.22 and ISO 8528.

13. WARRANTY

All of the Generating Sets are covered under a warranty policy for a period of 24 months. Warranty of the equipment is in line with manufacturers warranty terms & conditions.

(check warranty statement for more details, as it may vary for different countries)

In line with continuous product development, we reserve the right to change specifications without notice.

STANDARD REFERENCE CONDITIONS

Rating Definitions

Prime Power: Variable load. Unlimited hours usage with an average load factor of 80% of the published prime power over each 24 hour period. A 10% overload is available for 1 hour in every 12 hours of operation.

Standby Power: Variable load. Limited to 500 hours annual usage, up to 300 hours of which may be continuous running. No overload is permitted.

DIMENSIONS AND WEIGHT

Length cm	Width cm	Height cm	Weight* kg (wet)
127	54	107	400

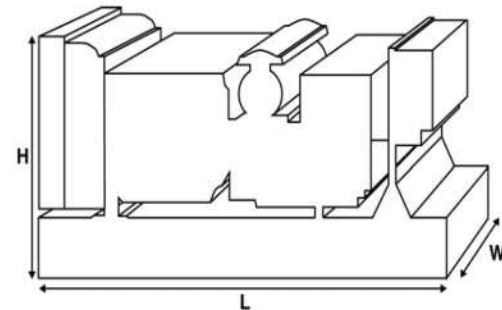

RM Services (Pvt) Ltd

Dealer contact details



Contact us
+92 317 245 7898

www.rmstpvt.com
info@rmstpvt.com

Address:
LA-10/1, Block-22 Federal B Area
Karachi, Pakistan