



Image for illustrative Purposes only.

GENERATING SET MODEL (RMS-C200)

1500 rpm (50 Hz Ratings)

Gross Engine Output			Net Engine Output			Typical Generator Set Output					
Standby	Prime	Base	Standby	Prime	Base	Standby (ESP)		Prime (PRP)		Base (COP)	
kWm/BHP			kWm/BHP			kWe	kVA	kWe	kVA	kWe	kVA
203/272	183/245	149/200	192/257	172/230	139/232	176	220	160	200	120	150

General Engine Data

Engine Model	6CTAA8.3-G2
Type	4 cycle, in-line, turbo charged, air to air cooled
Bore mm	114 mm
Stroke mm	135 mm
Displacement Litre	8.3 litre
Cylinder Block	Cast iron, 6 cylinder
Battery Charging Alternator	40 amps
Starting Voltage	24 volt
Fuel System	Direct injection
Fuel Filter	Spin-on fuel filters with water separator
Lube Oil Filter Type(s)	Spin-on full flow filter
Lube Oil Capacity (l)	23.8

Coolpac Performance Data

Cooling System Design	Charge air cooled
Coolant Ratio	50% ethylene glycol; 50% water
Coolant Capacity (l)	32
Limiting Ambient Temp.(°C)**	50
Fan Power(kWm)	9
Cooling System Air Flow (m ³ /s)**	4.27
Air Cleaner Type (Normal Duty)	Dry replaceable element with restriction indicator

** @ 13 mm H₂O at 100% Prime

Fuel Consumption 1500 (50 Hz)

%	kWm	BHP	L/ph	US gal/ph
Standby Power				
100	203	272	50	13.2
Prime Power				
100	183	245	45	11.9
75	137	184	34	9.0
50	91	122	23	6.1
25	46	62	13	3.4
Continuous Power				
100	149	200	36	9.5

ALTERNATOR DATA

Make	Stamford / Leroy Somer
Model	UC1274H / TAL046B
No. of bearings	1
Insulation class	H
Wires	12
Ingress Protection	IP23
Excitation System	SELF
Winding Pitch	2/3
AVR Model	AS440/SX460
Overspeed	2250 mn ⁻¹
Voltage Regulation (steady)	± 1%

CONTROL PANEL

Make	Deep Sea
Model	7000 SERIES

The DSE 7000 Series is an Auto Start Control Module for single genset applications. It includes a backlit LCD display which clearly shows the status of the engine all the times. This module can either be programmed using the front panel or by using the DSE configuration suite PC software.

Metering and Alarm indications:

- Generator frequency
- Underspeed, Overspeed
- Generator volts (L-L, L-N)
- Generator current
- Engine oil pressure
- Engine coolant temperature
- Fuel level (Warning or shutdown) - Optional
- Hours run counter

1. ENGINE

Cummins four stroke heavy duty high performance industrial type diesel engine.

2. ENGINE FILTRATION SYSTEM

- Cartridge type dry air filter.
 - Two Cartridge type fuel filters.
 - Full flow lube oil filter.
- All filters have replaceable elements.

3. COOLING RADIATOR

Radiator and cooling fan, complete with safety guards, designed to cool the engine at high ambient temperatures (consult your dealer for de-rating factors)

4. EXHAUST SYSTEM

Heavy duty Industrial Exhaust Silencer

- Silencer noise reduction level
- Maximum allowable back pressure

5. CIRCUIT BREAKRT TYPE

ABB 3 pole MCCB. (4 pole is optional)

6. FUEL SYSTEM

The baseframe design is incorporated with an integral fuel tank with a capacity of approx. 8 hours running at Full Load. The tank is supplied complete with fill cap breather, fuel feed and return lines to the Engine and drain plug.

STANDARD REFERENCE CONDITIONS

Rating Definitions

Prime Power: Variable load. Unlimited hours usage with an average load factor of 80% of the published prime power over each 24 hour period. A 10% overload is available for 1 hour in every 12 hours of operation.

Standby Power: Variable load. Limited to 500 hours annual usage, up to 300 hours of which may be continuous running. No overload is permitted.

- Battery volts
- Fail to start/stop
- Emergency stop
- Failed to reach loading voltage/frequency
- Charge fail
- Loss of magnetic pick-up signal - Optional
- Low DC voltage
- CAN diagnostics and CAN fail/error

7.ALTERNATOR

7.1 INSULATION SYSTEM

- The insulation system is Class H.
- All windings are impregnated in either a triple dip thermosetting liquid, oil and acid resisting polyester varnish or vacuum pressure impregnated with a special polyester resin.
- Heavy coat of antitracking varnish additional protection against moisture or condensation.

7.2 AUTOMATIC VOLTAGE REGULATOR (AVR)

The fully sealed Automatic Voltage Regulator maintains the Voltage Regulation at $\pm 1\%$. Nominal adjustment by means of a trim pot incorporated on the AVR.

8. MOUNTING ARRANGEMENT

8.1 COUPLING

The Engine and Alternator are directly coupled by means of an SAE flange. The Engine flywheel is flexibly coupled to the Alternator rotor.

8.2 ANTI-VIBRATION MOUNTING PADS

Anti-Vibration pads are affixed between the Engine / Alternator feet and the Baseframe thus ensuring complete vibration isolation of the rotating assembly.

8.3 SAFETY GUARDS

The Fan & Fan Drive along with the Battery Charging Alternator are Safety Guard protected for personnel protection.

9. FACTORY TEST

- The Generating set is load tested before dispatch
- All protective devices control functions and site load conditions are simulated. The generator and it's systems are checked before dispatch.

10. EQUIPMENT FINISHING

All mild steel components are fully degreased and painted with powder coated paint to ensure maximum scuff resistance and durability.

11. DOCUMENTATION

Operation & Maintenance manual, Circuit wiring diagrams and Commissioning / Fault Finding instruction leaflets are accompanied with the Generator.

12. QUALITY STANDARDS

The equipment meets the following standards: BS4999, BS5000, BS5514 IEC 60034, VDE0530, NEMA MG 1.22 and ISO 8528.

13. WARRANTY

All of the Generating Sets are covered under a warranty policy for a period of 24 months. Warranty of the equipment is in line with manufacturers warranty terms & conditions.

(check warranty statement for more details, as it may vary for different countries)

In line with continuous product development, we reserve the right to change specifications without notice.

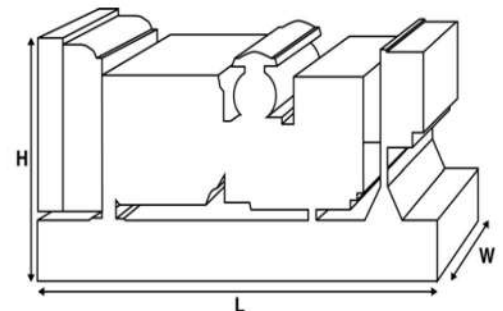

RM Services (Pvt) Ltd

Dealer contact details



 **Contact us**
+92 317 245 7898

 www.rmspvt.com
 info@rspvt.com

 **Address:**
LA-10/1, Block-22 Federal B Area
Karachi, Pakistan